

TECHNICAL DESCRIPTION / INSTALLATION INSTRUCTIONS

EASYFAN

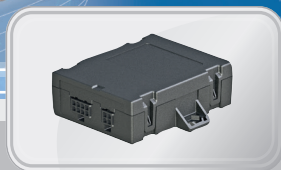

VALID FOR THE FOLLOWING CONTROL BOXES:

EasyFan, CAN bus high	24 0357 00 00 00
EasyFan, CAN bus low	24 0359 00 00 00

CONTENTS

CHAPTER	CHAPTER TITLE	
PAGE	CHAPTER CONTENTS	
1	INTRODUCTION	
	General information	3
	Important information before starting work	3
	Statutory regulations	3
	Hazard information and safety instructions for installation and operation	4
	Accident prevention	4
2	INSTALLATION	
	Scope of supply	5
	Installing the control box	5
3	ELECTRICAL CONNECTION	
	Connecting the control box	6
	Pin assignments	6
	Parts list	6
	Cable colours	6
	Circuit diagram	7
4	AREA OF USE / FUNCTIONAL DESCRIPTION	
	Area of use	8
	Functional description	8
5	CONTROL BOX PARAMETERISATION	8
	Parameterisation by the installation workshop	8
6	DIAGNOSIS AND TROUBLESHOOTING	9
	Features that can occur following installation or during the initial commissioning.	9
	Features that can occur during operation.	10
7	ENVIRONMENT	
	Certification	11
	Disposal	11
8	TECHNICAL DATA	
	CAN bus High / low	12

1 INTRODUCTION

GENERAL INFORMATION

This documentation applies to the control boxes listed on the title page, to the exclusion of all liability claims.

Depending on the version or revision status of the control boxes, differences may occur compared to this documentation.

This documentation helps the installation workshop to install the control box.

IMPORTANT INFORMATION BEFORE STARTING WORK

PLEASE READ FIRST

Before you start to install the control box, please ensure you read through this documentation carefully. The documentation contains important information, which you require for the installation.

NOTE

In addition, follow the statutory regulations, the additional regulations and the safety instructions in the documentation / CD enclosed with the heater.

AREA OF USE

The control box is intended for installation in the HVAC system (Heating, Ventilation and Air-Conditioning system) of M and N class vehicles.

INTENDED USE

The control box is solely for controlling the vehicle's own blower in motor vehicles.

ATTENTION!

Damage to the unit

Use, operation and deployment of the control box outside the range given by the manufacturer can cause considerable damage.

→ Only use the control box for the stipulated purpose and in the approved area of use.

STATUTORY REGULATIONS

The Federal Motor Transport Authority has issued an approval for a component with an official type-approval marking – noted on the nameplate.

Control box type	ECE type-approval marking
EasyFan	 10 R – 047598

NOTE

- Compliance with the statutory regulations, the additional regulations and the safety instructions is prerequisite for guarantee and liability claims.
- Failure to comply with the statutory regulations and the safety instructions make the guarantee null and void and excludes any liability of Eberspächer Climate Control Systems GmbH & Co. KG.
- Installation of the control box in special vehicles must comply with the regulations applying to such vehicles.
- Further installation requirements are printed in the relevant sections of these installation instructions.

1 INTRODUCTION

HAZARD INFORMATION AND SAFETY INSTRUCTIONS FOR INSTALLATION AND OPERATION



DANGER!

Risk of injuries

- ➔ Disconnect the vehicle battery before starting any kind of work.

Safety instructions

- The control box may only be installed by a JE partner authorised by the manufacturer according to the specifications in this documentation and any special installation recommendations.
- Only original parts, original accessories and original spare parts may be used for installation or repairs.
- Repairs to the control box are not permitted.
- The following measures are not allowed:
 - Use of third-party components not approved by Eberspächer Climate Control Systems GmbH & Co. KG.
 - Deviations from the statutory, safety and / or functionally relevant requirements stated in this technical description and installation instructions.
- In case of electric welding work on the vehicle, disconnect the positive pole from the battery and connect it to earth.
- Replace defective fuses only with fuses with the specified fuse rating.

ACCIDENT PREVENTION

Always follow all accident prevention regulations and shop and operating safety instructions.

2 INSTALLATION

SCOPE OF SUPPLY

Order No. 24 0357 00 00 00 / 24 0359 00 00 00

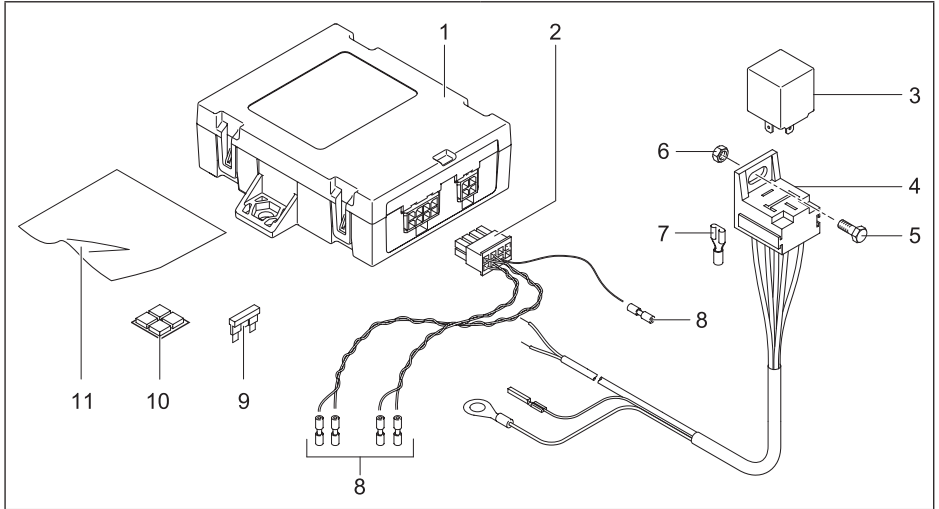

- | | | | |
|---|-----------------------------------|----|--------------------------------|
| 1 | Control box | 7 | Cable lug contact, relay block |
| 2 | Lead harness with 8-pin connector | 8 | Quick-release connector |
| 3 | Micro relay | 9 | Fuse, 5A |
| 4 | Base with lead harness | 10 | Adhesive pads |
| 5 | Screw, M5 × 10 (1x) | 11 | Cleaning cloth |
| 6 | Hexagon nut, M5 (1x) | | |

INSTALLING THE CONTROL BOX

The control box must be installed inside the vehicle; the preferred location is under the dashboard.

Use screws or adhesive pads to fix the blower control box in a protected place inside the vehicle with sufficient distance from components that become hot.

Clean the mounting surface before fixing the control box. Use the cleaning cloth supplied.

i NOTE

- When installing the control box ensure there is sufficient space available to connect the connector.
- When drilling the fixing holes for the control box, vehicle parts behind the mounting area must not be damaged.

3 ELECTRICAL CONNECTION

CONNECTING THE CONTROL BOX

Connect the 4-pin connector of the heater lead harness to the control box.

Use a quick-release connector to connect the BKRD cable from the heater lead harness (blower output) and the BKRD cable from the control box lead harness (8-pin connector, PIN 7).

Further electrical connection as specified in the installation recommendation of the vehicle or with the circuit diagram.

The installation recommendation and circuit diagram are available to view and to download from the Eberspächer Service Portal.

i NOTE

Use a suitable crimping tool to connect cables with butt-type connectors 0.3 to 0.5.

PIN ASSIGNMENTS

8-PIN CONNECTOR

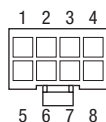

Connector shown from the cable inlet side.

PIN	Connection
1	CAN bus high, to the air-conditioning control unit / air-conditioning control box
2	CAN bus low, to the air-conditioning control unit / air-conditioning control box
3	unused
4	Relay output
5	CAN bus high, to the vehicle
6	CAN bus low, to the vehicle
7	Switch input / heater
8	unused

4-PIN CONNECTOR



Connector shown from the cable inlet side.

PIN	Connection
1	Terminal 30 (+)
2	Internal CAN bus, high
3	Terminal 31 (-)
4	Internal CAN bus, low

PARTS LIST

- Axx EasyFan control box
- A30 Fuse holder 3-pin
- F1 Heater fuse, 20A
- F2 Control unit fuse, 5A
- F3 Fan relay fuse, 5A
- K1 Fan relay
- XB6/3 Bush housing EasyFan control box, 4-pin
- XB7 Relay block
- XBx/x Bush housing EasyFan control box, 8-pin
- XX1 Butt-type connector

- a from the heater cable harness
- b Activation CAN bus air-conditioning control unit / air-conditioning control box
- c to the CAN bus air-conditioning control unit / air-conditioning control box and the vehicle CAN bus

CABLE COLOURS

RD	red	GR	grey	BK	black
BU	blue	YE	yellow	GN	green
WH	white	VT	violet	BN	brown
OR	orange				

3 ELECTRICAL CONNECTION

CIRCUIT DIAGRAM

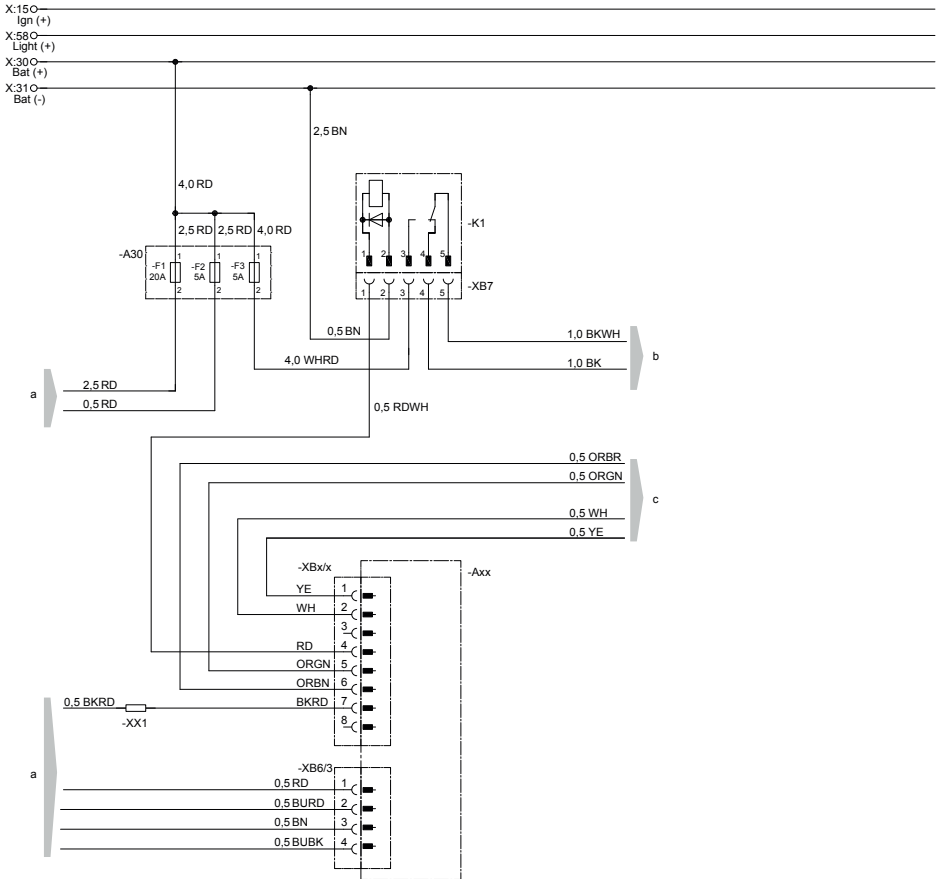

For parts list, see Page 6

4 AREA OF USE / FUNCTIONAL DESCRIPTION

AREA OF USE

The blower control box controls the vehicle blower during operation of pre-heaters in motor vehicles and adjusts the air ducting dampers.

This enables optimum heating of the vehicle interior, independent of the air-conditioning control unit's settings.

FUNCTIONAL DESCRIPTION

The blower control box is activated when parking heating begins.

The following occur automatically:

- the vehicle blower motor is switched on,
- the temperature is set to “Hot”,
- the dampers of the air ducting are set to “Defrost (Def)”.

If a vehicle door is unlocked or opened during pre-heater mode or a window lift is actuated the air-conditioning control unit and the vehicle blower are switched off.

If, with heating mode still active, the control box does not receive any further signals from the air-conditioning control unit within a pre-defined time the control box one again controls the blower.

The vehicle blower motor is switched on again, the temperature setting is set to “Hot” and the air system dampers are set to “Defrost (Def)”.

If the vehicle is started during pre-heating mode the blower control box transfers control to the air-conditioning control unit, the air-conditioning settings switch to the original settings and can be adjusted as usual to the user's personal preferences.

5 CONTROL BOX PARAMETERISATION

PARAMETERISATION BY THE INSTALLATION WORKSHOP



NOTE

The EasyScan diagnostic tool is required to parameterise the control box. For detailed information refer to the EasyScan operating instructions.

SETTING THE PARAMETERS

After installing the control box at the diagnostic connector of the heater cable harness, connect the EasyScan diagnostic tool.

Download the parameter set for the relevant vehicle from the Eberspächer Service Portal and transfer to the control box with EasyScan.

Note the 14-digit number of the parameter set on the nameplate.

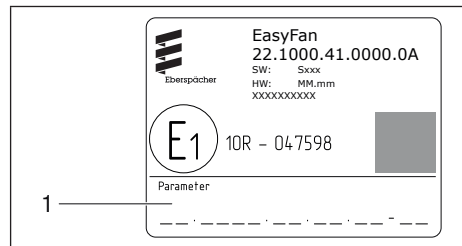

- 1 Enter the 14-digit number of the parameter set here.

5 CONTROL BOX PARAMETERISATION

DISCONNECT THE CONTROL BOX FROM THE POWER SUPPLY

After installing and parameterising the control box, disconnect it from the power supply:

- Unplug the 4-pin connector from the control box,
- Wait for 3 seconds,
- Plug the 4-pin connector back into the control box.

FUNCTIONAL CHECK

Switch on the heater, **don't** start the vehicle engine.

At a cooling liquid temperature of 30 °C the blower motor must start up and after a short time, hot air flows out of the defroster nozzles.

Correct any faults that occur using the remedial actions of the troubleshooting.

6 DIAGNOSIS AND TROUBLESHOOTING

FEATURES THAT CAN OCCUR FOLLOWING INSTALLATION OR DURING THE INITIAL COMMISSIONING.

The vehicle blower can be activated in pre-heater mode	The air dampers can be activated in pre-heater mode	EasyFan is displayed in EasyScan	If the Ignition is ON the air-conditioning control unit is switched on, the control unit is visible in the vehicle diagnostics	Flashing warning lights in the combined instrument	EasyFan relay noise if Ignition OFF and after vehicle CAN bus idle phase	EasyScan can perform a self-check	Use EasyScan to check the parameter set	Remedial action
X	X	X	–	X ²⁾	X	X	X	▪ Check the CAN bus to the vehicle, if necessary connect the cables correctly.
X ¹⁾	X ¹⁾	X	X	–	X	X	–	▪ Select the parameter set for the vehicle in the Service Portal.
X ¹⁾	X ¹⁾	X	X	–	X	X	X	▪ Check the EasyFan part number, if necessary replace the EasyFan.
–	–	X	X	X ³⁾	X	(X)	X	▪ Check the CAN bus to the vehicle and to the air-conditioning control unit, if necessary replace the CAN bus.
–	–	X	X	–	X	X	X	▪ In PIN 7 of the 8 pin connector, check whether the “switch input” cable is connected, if necessary plug in the cable or rearrange the pin assignment.
–	–	X	X	–	X	X	–	▪ In PIN 4 of the 8 pin connector, check whether the “relay output” cable is connected. Plug in the correct cable or rearrange the cable assignment. ▪ Select the parameter set for the vehicle in the Service Portal and parameterise the EasyFan.
–	–	X	X	–	X	–	X	▪ Check the EasyFan part number, if necessary replace the EasyFan.
–	–	X	–	X ²⁾	X	–	X	▪ Check the CAN bus to the air-conditioning control unit, if necessary replace the cables.
–	–	X	–	–	–	–	X	▪ Check 8-pin connector lock.
–	–	–	X	–	–	–	–	▪ Check 4-pin connector lock. ▪ Check the connection of the red cable (+) and brown cable (–, earth), if necessary swap the cables.

1) Possible 2) Driving mode 3) Pre-heating mode

6 DIAGNOSIS AND TROUBLESHOOTING

FEATURES THAT CAN OCCUR DURING OPERATION.

The vehicle blower can be activated in pre-heater mode	The air dampers can be activated in pre-heater mode	EasyFan is displayed in EasyScan	If the ignition is ON the air-conditioning control unit is switched on. The control unit is visible in the vehicle diagnostics	The air-conditioning control unit wakes up in pre-heating mode	EasyFan relay noise if ignition OFF and after vehicle CAN bus idle phase	EasyScan can perform a self-check	Remedial action
–	–	–	X	–	–	–	4-pin connector: check PIN 1 cable for correct contact, continuity, short-circuit and damage.
X	X	–	X	–	X	–	4-pin connector: check PIN 2 cable for correct contact, continuity, short-circuit and damage.
–	–	–	X	–	–	–	4-pin connector: check PIN 3 cable for correct contact, continuity, short-circuit and damage.
X	X	–	X	–	X	–	4-pin connector: check PIN 4 cable for correct contact, continuity, short-circuit and damage.
–	–	X	–	–	X	–	8-pin connector: check PIN 1 cable for correct contact, continuity, short-circuit and damage.
–	–	X	–	–	X	–	8-pin connector: check PIN 2 cable for correct contact, continuity, short-circuit and damage.
–	–	X	X	–	X	–	8-pin connector: check PIN 4 cable for correct contact, continuity, short-circuit and damage.
X	X	X	–	X	X	X	8-pin connector: check PIN 5 cable for correct contact, continuity, short-circuit and damage.
X	X	X	–	X	X	X	8-pin connector: check PIN 6 cable for correct contact, continuity, short-circuit and damage.
–	–	X	X	–	X	X	8-pin connector: check PIN 7 cable for correct contact, continuity, short-circuit and damage.



NOTE FOR THE INSTALLATION WORKSHOP

ERROR ENTRY IN THE VEHICLE DIAGNOSTIC SYSTEM

If the vehicle bus is woken up during pre-heating mode, e.g. by opening a vehicle door, ignition ON, a CAN communication error can possibly result in an entry in the vehicle diagnostic system.

This entry does not affect the functional capability of the vehicle and heater; however it is listed in the error log of the vehicle diagnostics system.

7 ENVIRONMENT

CERTIFICATION

The high quality of Eberspächer products is the key to our success.

To guarantee this quality, we have organised all work processes in the company along the lines of quality management (QM).

Even so, we still pursue a large number of activities for continuous improvement of product quality in order to keep pace with the similarly constantly growing requirements made by our customers.

All the steps necessary for quality assurance are stipulated in international standards. This quality is comprehensive. It concerns products, processes and customer - supplier relationships.

Officially approved public experts assess the system and the corresponding certification company awards a certificate.

Eberspächer Climate Control Systems GmbH & Co. KG has already qualified for the following standards:

Quality management in accordance with EN ISO 9001:2008 and ISO/TS 16949:2009

Environmental management system in accordance with EN ISO 14001:2004

DISPOSAL

DISPOSAL OF MATERIALS

Old units, defective components and packaging materials can be separated into their individual materials so that if necessary all parts can be disposed of in an environmentally friendly way or can be recovered and reused.

Electric motors, control boxes and sensors (e.g. temperature sensors) are deemed to be “electronic scrap”.

PACKAGING

Keep the packaging in case components have to be returned.

8 TECHNICAL DATA

CAN BUS HIGH / LOW

Rated voltage [V]		12
Operating voltage [V]		min. 8, max. 16
Overvoltage [V]		max. 18 (max. 1 h)
Jump start [V]		max. 26 (max. 1 min.)
Current input [mA]		50, max. 1700
Closed-circuit current input [μ A]		95
Temperatures [°C]	Storage	– 40 to + 90
	Operation	– 40 to + 85
	Environment	– 40 to + 70
Humidity [%]	Storage (non-condensing)	5 to 85
	Operation (non-condensing)	5 to 85
Dimensions [mm]	without fixing tabs	L: 57 / W: 76 / H: 22.5
	with fixing tabs	L: 71.8 / W: 76 / H: 22.5
Degree of protection [IP]		40

Eberspächer Climate Control Systems
GmbH & Co. KG
Eberspächerstraße 24
73730 Esslingen
Hotline: 03976 2350235
Fax hotline: 01805 262624
info@eberspaecher.com
www.eberspaecher.com

